

INCH serration

- LARGE THROUGH HOLE
- 3 jaws

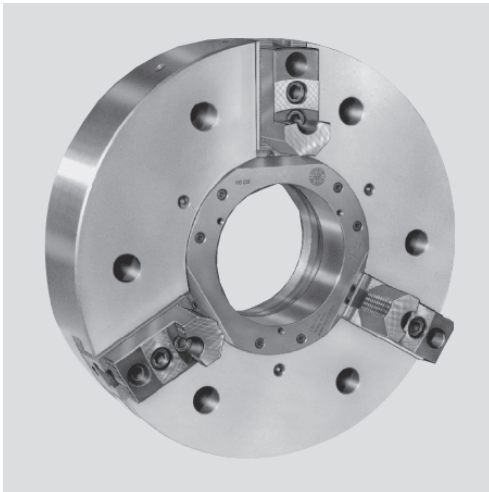

Application/customer benefits

- For open center or partial open center clamping
- Large through-hole

BH-D: Master jaws with INCH serration 3/32" x 90°

Technical features

- Gripping force transmission via wedge hook

Standard equipment

- 3 jaw chuck
- 1 set T-nuts with bolts
- 1 set soft top jaws
- Blank ring-nut
- Mounting bolts
- Grease gun

Ordering example

- 3 jaw chuck BH-D 500/A15
- or
- 3 jaw chuck BH-D 800/FL520

Actual gripping force diagram

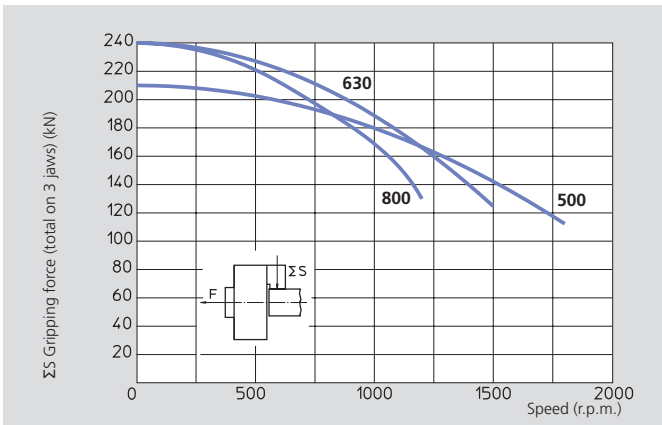

The data in the diagram refer to 3-jaw-chucks, newly maintained according to their service manuals using SMW-AUTOBLOK K05 grease. The static and dynamic gripping forces have been measured using standard soft top jaws, placed in a position not exceeding the outer diameter of the chuck.

⚠ Safety advice/danger of damage:

When using taller/heavier jaws and/or clamping on a bigger diameter reduce draw pull/rotating speed accordingly.

Technical data

SMW-AUTOBLOK Type		BH-D 500	BH-D 630	BH-D 800
Number of jaws		3	3	3
Through-hole	mm	180	230	230
Radial jaw stroke	mm	6.5	9	9
Axial piston stroke	mm	31	34	34
Max. draw pull	kN	70	100	100
Max. gripping force	kN	210	240	240
Max. speed	r.p.m.	1800	1500	1200
Weight (without top jaws)	kg	140	280	530
Moment of inertia	kg·m ²	5	16	47
Recommended actuating cylinders		SIN-S 150/200 VSG 450-165	SIN-S 150/200 VSG 550-205	SIN-S 150/200 VSG 550-205



Page 304

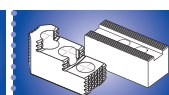

Page 306

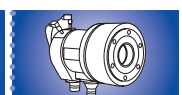

Page 217

- LARGE THROUGH HOLE
- 3 jaws

INCH serration

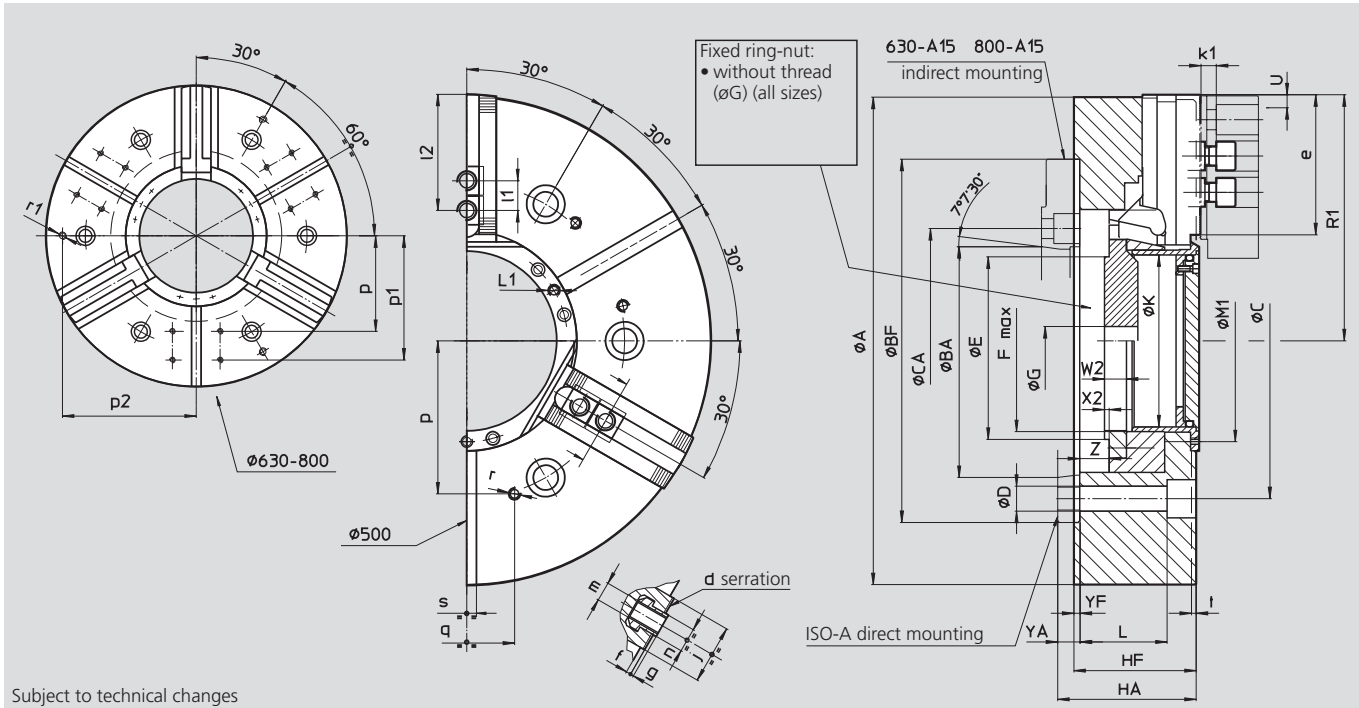

Subject to technical changes
For more detailed information please ask for customer drawing

SMW-AUTOBLOK Type			BH-D 500		BH-D 630			BH-D 800		
Mounting			FL380	A15	FL520	A15	A20	FL520	A15	A20
	A	mm	510		630			800		
	Bf/BA H6	mm	380	285.775	520	285.775	412.775	520	285.775	412.775
	C	mm	330.2		463.6	-	463.6	463.6	-	463.6
	CA	mm	-	-	-	330.2	-	-	330.2	-
	D	mm	26		26			26		
	E	mm	206		260			260		
	Fmax	mm	M195 x 3 (*)		M250 x 3 (*)			M250 x 3 (*)		
	G	mm	30		30			30		
	Hf/HA	mm	128	145	150	184	169	150	184	169
	K	mm	180		230			230		
	L	mm	91		99			99		
	L1	mm	M8/9		M8/16			M8/16		
	M1	mm	211		270			270		
Chuck open	R1	mm	257.5		314			399		
Jaw stroke	U	mm	6.5		9			9		
	W2	mm	23		23			23		
	X2	mm	5		5			5		
	Yf/YA	mm	6	23	6	40	25	6	40	25
max./min.	Z	mm	31/0		34/0			34/0		
BH-D serration	d	inch	3/32" x 90°		3/32" x 90°			3/32" x 90°		
	e	mm	146.5		152			237		
	f	mm	5		10			10		
	g	mm	3.5		3.5			3.5		
	j	mm	62		62			62		
	k1	mm	16		16			16		
	l1	mm	38		38			38		
max./min.	l2	mm	121/53		127/53			212/53		
	m	mm	M20		M20			M20		
	n h8	mm	25.5		25.5			25.5		
	p	mm	160		200			200		
	p1	mm	-		260			260		
	p2	mm	-		280			280		
	q	mm	100		100			100		
	r	mm	M12/22		M12/22			M12/22		
	r1	mm	-		M16/28			M16/28		
	s H12	mm	20		20			20		
	t	mm	5		5			5		

(*) max possible thread on blank ring-nut.